

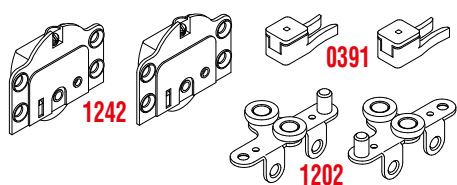

KIT 1202-1242 - MAX 50 KG

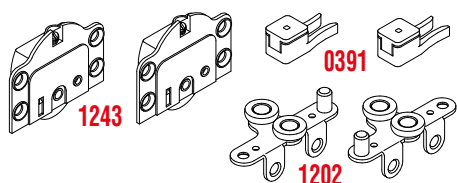

KIT 1202-1243 - MAX 50 KG



Legenda KIT / Kit Legend

1202	Guida superiore DX-SX <i>Upper runner left-right</i>
1242	Carrello inferiore regolabile con rullo <i>Lower adjustable truck with roller</i>
1243	Carrello inferiore regolabile con cuscinetto <i>Lower adjustable truck with ball bearing</i>
0391	Fermo superiore <i>Upper stopper</i>

Legenda altri componenti Legend other items

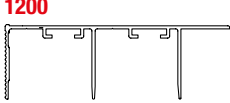
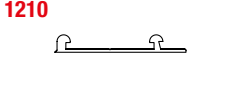
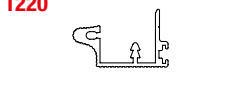
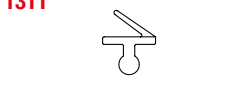
1200		Profilo alluminio superiore <i>Upper aluminium profile</i>
1210		Profilo alluminio inferiore <i>Lower aluminium profile</i>
1220		Profilo maniglia alluminio (per spessore 18-22mm) <i>Aluminium handle profile (for thickness 18-22mm)</i>
1311		Guarnizione plastica coestrusa (per ART.1220) <i>Co-extruded plastic profile (for ART.1220)</i>

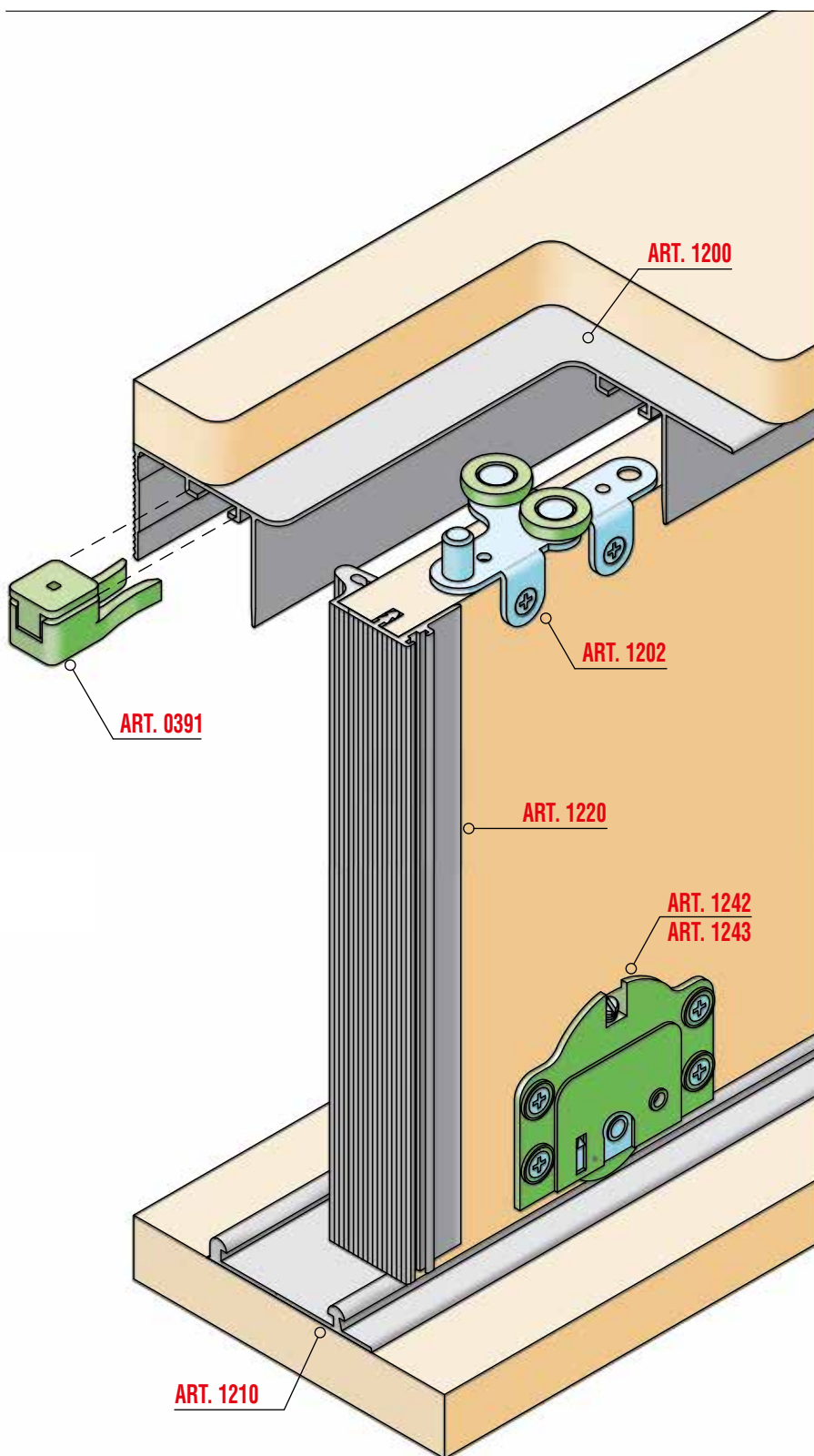



Sistemi scorrevoli per armadi / sliding systems for wardrobes

Sezione verticale / Vertical section

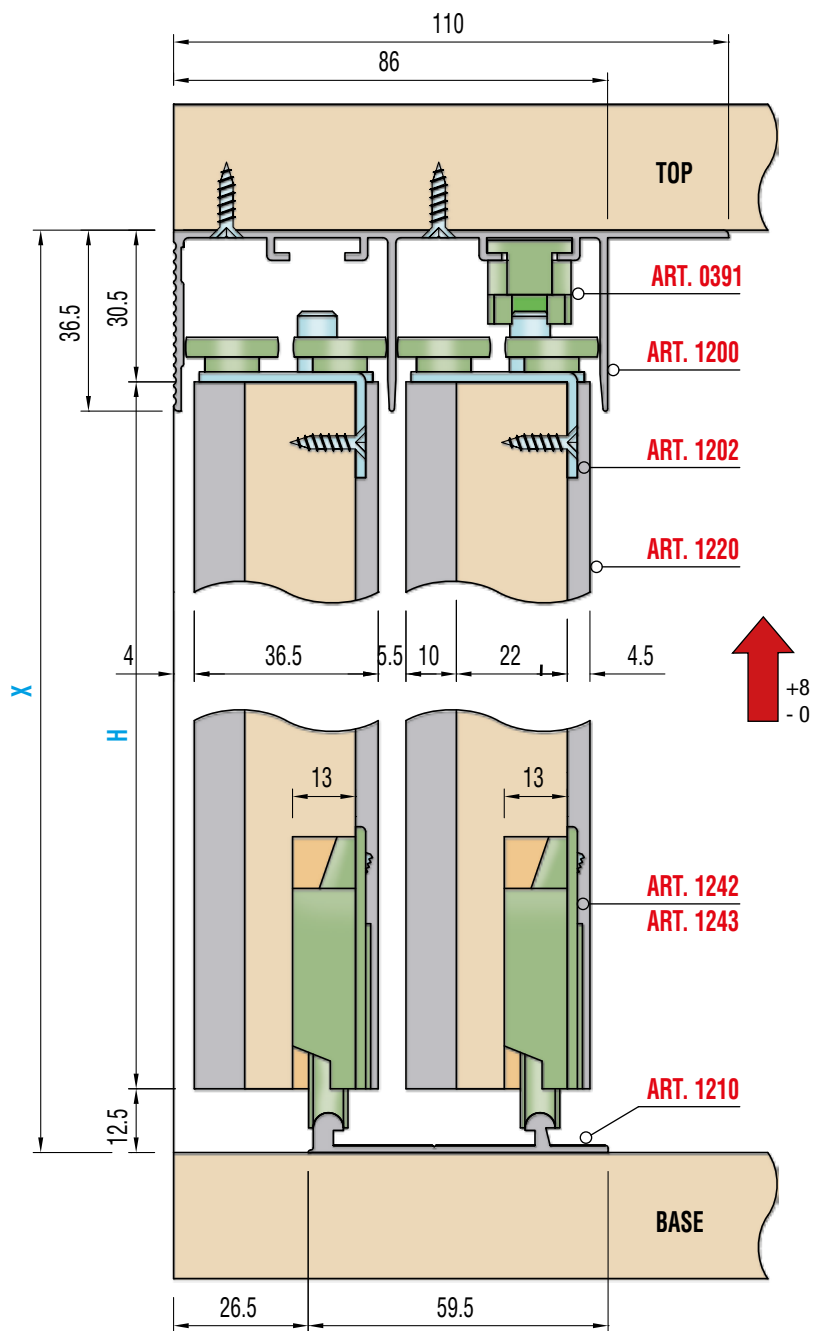

Peso massimo anta Kg. 50
Maximum door weight Kg 50

H = X - 43

Schema Foratura ante / Doors drilling

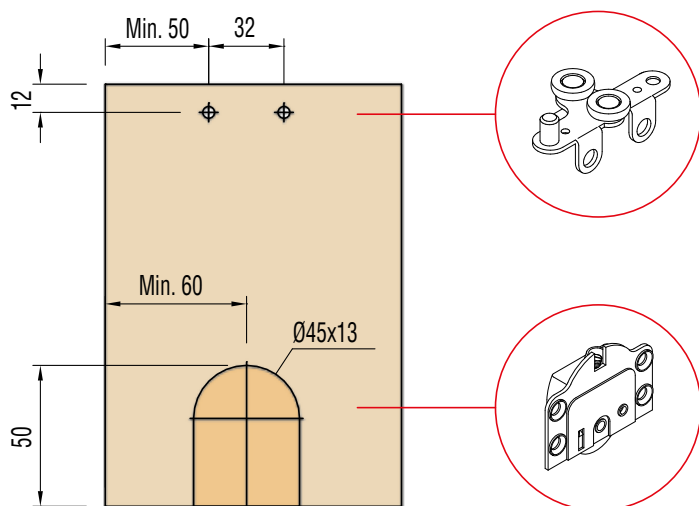



Sistemi scorrevoli per armadi / sliding systems for wardrobes

Schema foratura profili maniglia / Drilling handle profile

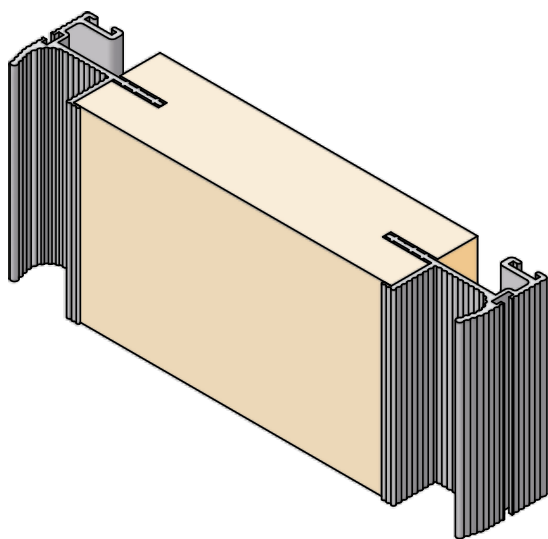

PROFILO MANIGLIA ART.1222 - HANDLE PROFILE ART.1222

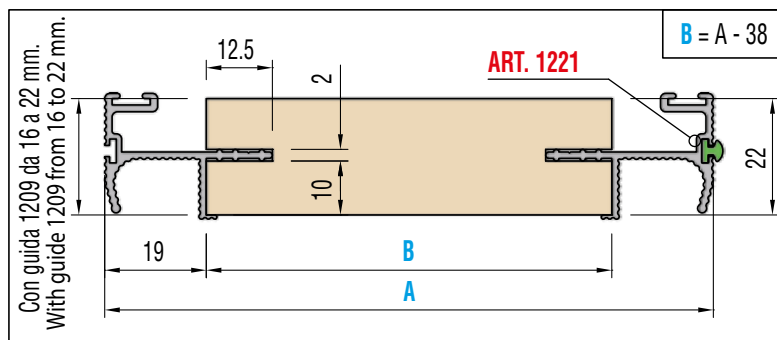

PROFILO MANIGLIA ART.1220 - HANDLE PROFILE ART.1220

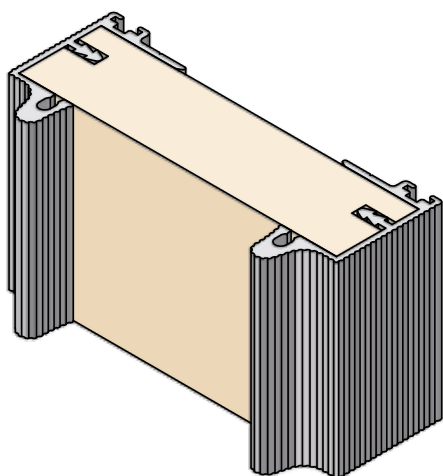
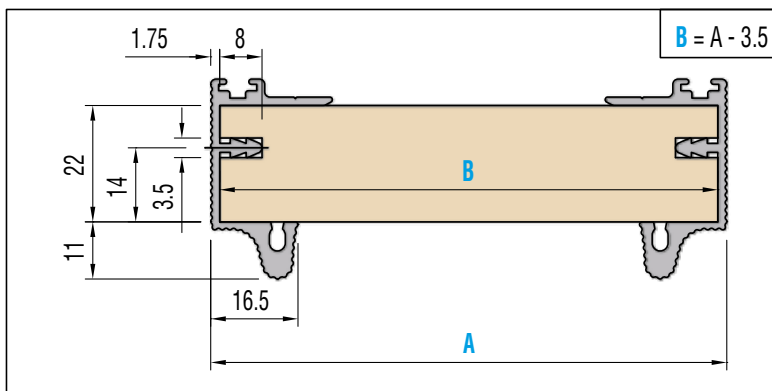

PROFILO MANIGLIA ART.1220 - HANDLE PROFILE ART.1220

